



The Archaeological Origin and Significance of the Dolphin Vase as Determined by Neutron Activation Analysis

Author(s): Patrick E. McGovern, Janine Bourriau, Garman Harbottle, Susan J. Allen

Source: *Bulletin of the American Schools of Oriental Research*, No. 296 (Nov., 1994), pp. 31-43

Published by: The American Schools of Oriental Research

Stable URL: <http://www.jstor.org/stable/1357178>

Accessed: 16/07/2009 14:40

Your use of the JSTOR archive indicates your acceptance of JSTOR's Terms and Conditions of Use, available at <http://www.jstor.org/page/info/about/policies/terms.jsp>. JSTOR's Terms and Conditions of Use provides, in part, that unless you have obtained prior permission, you may not download an entire issue of a journal or multiple copies of articles, and you may use content in the JSTOR archive only for your personal, non-commercial use.

Please contact the publisher regarding any further use of this work. Publisher contact information may be obtained at <http://www.jstor.org/action/showPublisher?publisherCode=asor>.

Each copy of any part of a JSTOR transmission must contain the same copyright notice that appears on the screen or printed page of such transmission.

JSTOR is a not-for-profit organization founded in 1995 to build trusted digital archives for scholarship. We work with the scholarly community to preserve their work and the materials they rely upon, and to build a common research platform that promotes the discovery and use of these resources. For more information about JSTOR, please contact support@jstor.org.



The American Schools of Oriental Research is collaborating with JSTOR to digitize, preserve and extend access to *Bulletin of the American Schools of Oriental Research*.

<http://www.jstor.org>

The Archaeological Origin and Significance of the Dolphin Vase as Determined by Neutron Activation Analysis

PATRICK E. MCGOVERN

Museum Applied Science Center for Archaeology (MASCA)
The University of Pennsylvania Museum of Archaeology and Anthropology
33rd and Spruce Sts.
University of Pennsylvania
Philadelphia, PA 19104

JANINE BOURRIAU

McDonald Institute for Archaeological Research
62 Sydney St.
Cambridge CB2 1JW
United Kingdom

GARMAN HARBOTTLE

Department of Chemistry
Brookhaven National Laboratory
Upton, NY 11973

SUSAN J. ALLEN

Egyptian Art Department
The Metropolitan Museum of Art
5th Avenue at 82nd St.
New York, NY 10028

The Dolphin Vase which was excavated from a Middle Kingdom Egyptian tomb at the capital city of Lisht, is so named because of its naturalistic depiction of dolphins. This pottery jug, dated ca. 1750–1700 B.C., epitomizes the network of international relations of a prosperous period: found in Egypt, the dolphins appear to be Minoan in style and yet the vessel shape and manufacture are of Levantine inspiration. Statistical evaluation of the chemical composition of its pottery ware by neutron activation analysis (NAA) makes it virtually certain that the Dolphin Vase originated in the Gaza region of southern Palestine. Trade relations between the latter region and Egypt, with consequent stylistic and technological exchange, intensified under the so-called “Hyksos,” a Semitic dynasty that controlled the eastern Nile Delta between ca. 1700 and 1550 B.C.

Pottery, as the most ubiquitous and well-preserved evidence of ancient cultures, has been a mainstay of archaeological interpretation—whether of chronology, social structure, or economic activity such as foreign trade. Increasingly, traditional approaches based on stylistic features are being expanded to include scientific analyses. In addition to their importance in reconstructing ancient technologies, such analyses can often provide definitive evidence of when,

where, and how a pottery vessel was made and used (e.g., McGovern 1989; Biers and McGovern 1990). This article illustrates the compelling force of one line of scientific evidence—the chemical composition of pottery wares—in establishing the origin (place of manufacture) of pottery. Whereas pottery shapes and decorations were readily transferred between cultures and consciously imitated, ancient potters generally were limited to locally available clays and exercised less control over

their chemical makeup. Consequently, the chemical composition of a pottery ware can be a very sensitive indicator of origin.

The Dolphin Vase (fig. 1) was recovered by a Metropolitan Museum of Art expedition (Mace 1921) in 1921 from Tomb 879 of a Middle Kingdom cemetery south of the northern pyramid at Lisht (fig. 2). The pottery vessel is a premier artifact of the museum's Egyptian Art Department.

The Lisht pyramid and the capital city to its east, known as *jꜥ-tꜣwj* in Egyptian ("seizer of the two lands"), were founded by the powerful pharaoh who inaugurated the Middle Kingdom (Dynasty 12), Amenemhet I (high 1979–1950 B.C.; low 1937–1908 B.C.).¹ Because of the close association of the pyramid precinct and the cemetery, the early excavators unequivocally assigned Tomb 879 to this king's reign. This exact dating, which has since been challenged (below), enabled far-flung chronological synchronisms to be made with other Near Eastern and Mediterranean cultures.

Under Amenemhet I and his successors, Egypt conquered territories as far south as the third cataract of the Nile in Nubia, and renewed contacts with the Levant. Preeminently at Byblos in Lebanon, the Semitic rulers were buried in full Egyptian regalia (Montet 1928–1929); these regalia evidently were gifts or payments in kind from two late Dynasty 12 pharaohs, Amenemhet III and IV (high 1859–1805 B.C.; low 1817–1763 B.C.), in exchange for cedar and other goods.²

STYLE AND MANUFACTURE OF THE DOLPHIN VASE

Reflecting Egypt's strong international position, the Dolphin Vase exhibits a high level of craftsmanship and a multicultural style. The realistic portrayal of the three leaping dolphins in side profile (fig. 1) captured the imagination of scholars, who argued that dolphins illustrated on Minoan vase paintings and frescoes served as prototypes for those on the Dolphin Vase (Kantor 1965: 23–24, fig. 6; Kemp and Merrillees 1980: 220–25, pl. 31; Warren and Hankey 1989: 135–37). The Minoan and Dolphin Vase representations share idiosyncratic features that differ from those of the common dolphin (*Delphinus delphis*), including horizontal wavy lines along the dolphins' lower bodies, perhaps to indicate color banding or the motion of waves; dorsal fins set too far forward relative to the pectoral flippers; and

tails that are vertically positioned and fluked rather than horizontal and notched (as communicated in a lecture by L. Onyshkevych, March 1992, University of Pennsylvania). Because the Minoan *comparanda* have now been shown generally to postdate the Dolphin Vase (Czernohaus 1988: 8–19, pl. 10: 2–14), however, any stylistic influence must now be seen to have gone in the opposite direction.

Significantly, the birds on the vase have no parallels on Crete. The ten birds, which are arranged in two groups of three and one group of four on the upper half of the vessel (fig. 1), are variously sized and shown in three-quarter rear profile. Their long necks and tails, erect plump bodies, and fairly well-defined toes, one apparently projecting backwards, suggest a wading bird of the stork, crane, or heron family, although a goose cannot be ruled out (Houlihan 1988: 13–18, 22–26, 54–62, 83–88).

The jug shape and details—a slightly piriform body; a high, tripartite loop-handle on the shoulder; and a rim that has been folded outward to form a flat ledge—are clearly related to pottery types that were common in the Syro-Palestinian area towards the end of MB IIA and continuing into early MB IIB (Kantor 1965; Weinstein 1982: 159–60, n. 4), ca. 1750–1700 B.C.³ The base of the vessel, although now missing, was probably a flat disk or ring base, in accord with comparable jugs. Macroscopic and X-ray examination indicates that the vessel was thrown on a wheel from a single lump of clay, only the handle having been attached separately to the shoulder with clay wads as reinforcement.

The Dolphin Vase evidently benefited from developments in the potter's craft. Following a several-hundred-year "Dark Age" during MB I, urban communities (city-states) began to develop in Palestine at about the same time as the founding of Lisht. Unlike the handmade, generally poorly fired, and rather poorly shaped vessels of MB I, the intensive use of the potter's wheel in MB IIA (high 1900–1740 B.C.; low 1875–1730 B.C.) led to the development of a new repertoire of consistently contoured, thin-walled, and evenly fired forms. Decorative effects—including highly polished slips and painted geometric designs—became common.

The Dolphin Vase's decoration combines several techniques, which were carried out sequentially as follows: (1) the dolphins' and birds' bodies were painted; (2) the animal bodies were outlined and detailed with grooves and lines of dots that punctured

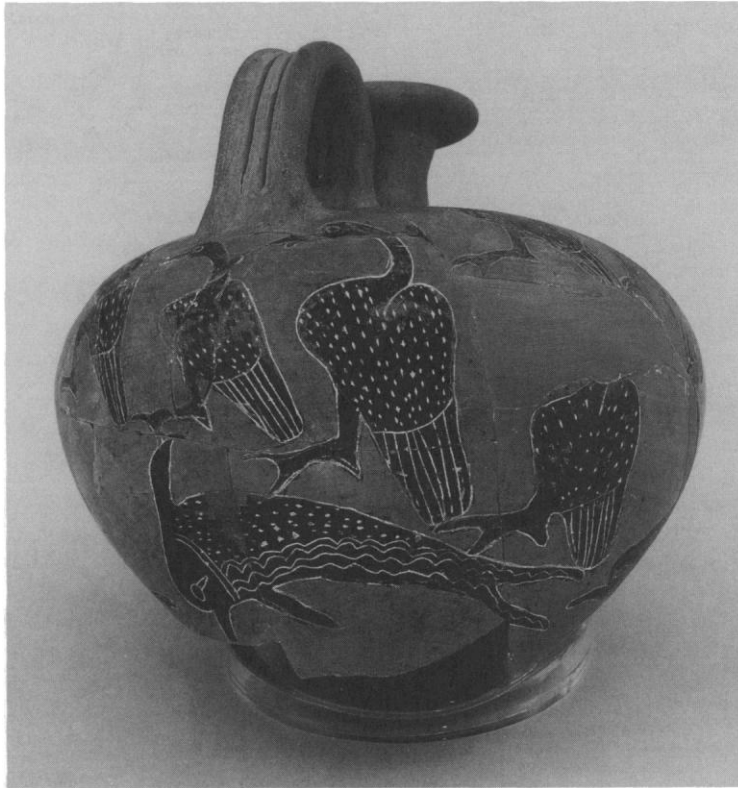
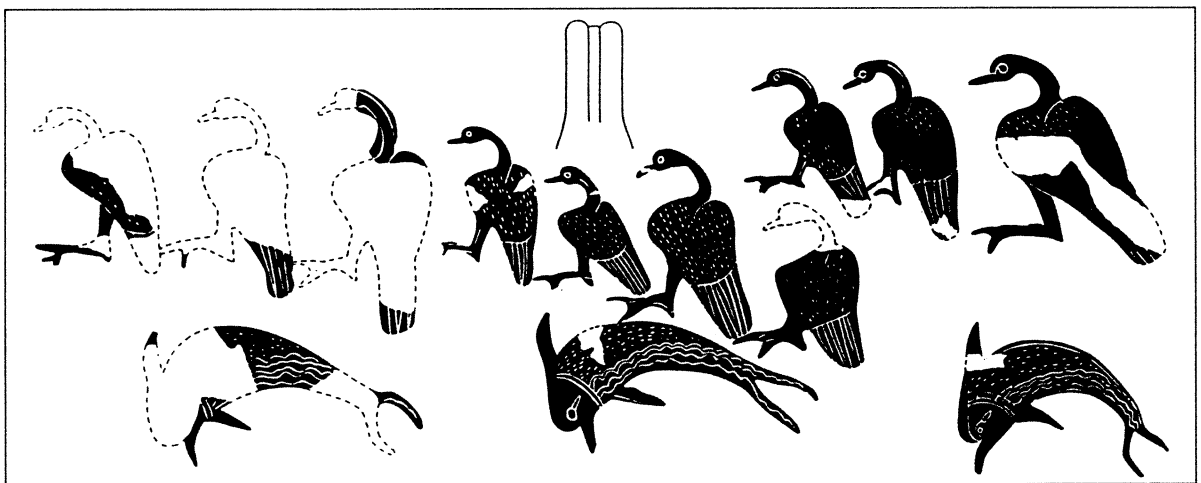

Fig. 1. The Dolphin Vase, from Lisht, Tomb 879; Metropolitan Museum of Art no. 22.1.95. The flattened-out view of the decoration (below) is half the size of the 1:3 photograph. Broken lines indicate reconstructed areas with traces of paint. Courtesy of the Metropolitan Museum of Art, Rogers Fund and Edward S. Harkness Gift, 1922.



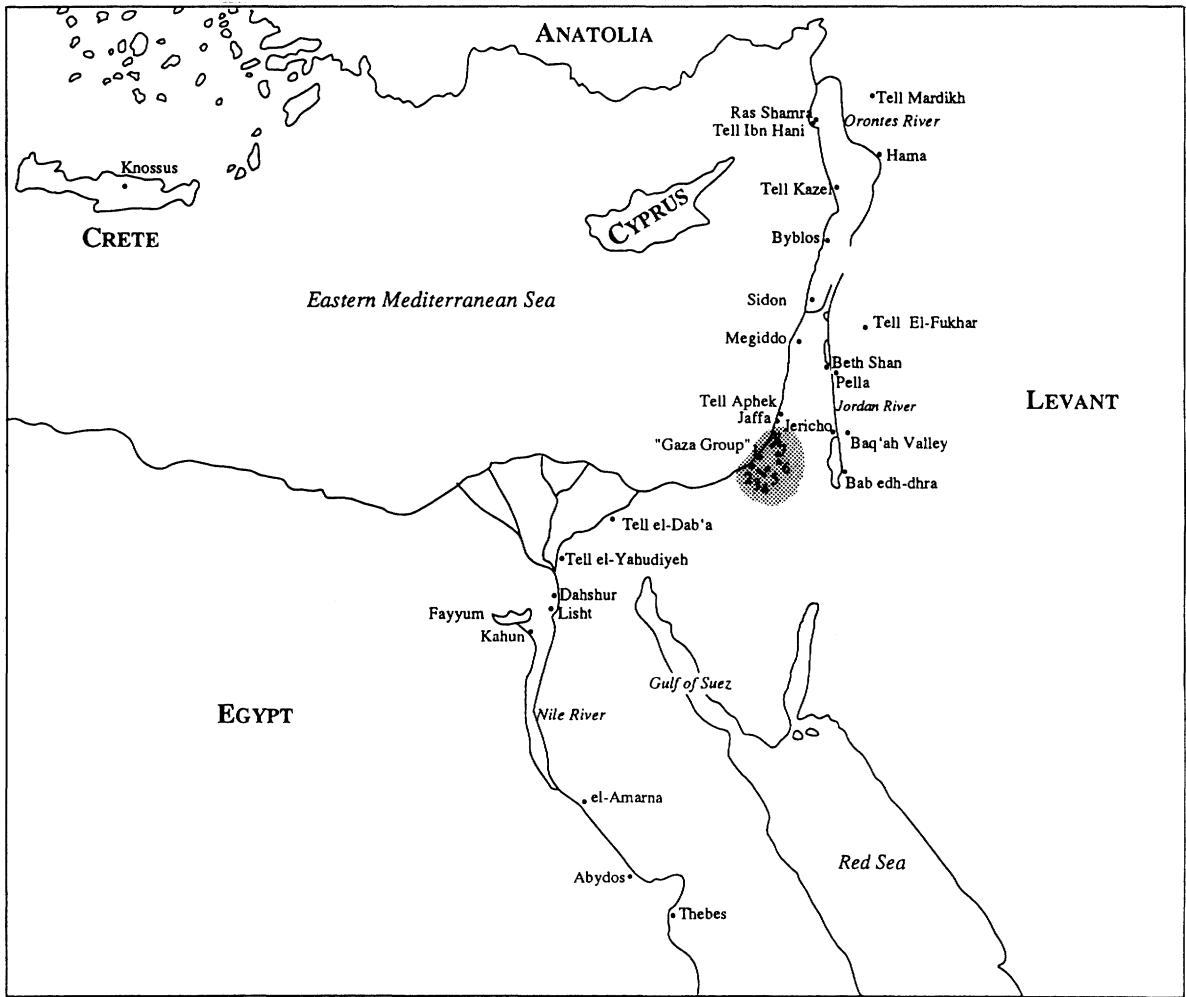

Fig. 2. Eastern Mediterranean, showing Middle Bronze Age sites and regions referred to in the text. The "Gaza group of Middle Bronze Age sites" includes: (1) Gaza; (2) Tell el-^cAjjul; (3) Tell Jemmeh; (4) Tell el-Far^cah South; (5) Tel Haror; (6) Tell Beit Mirsim; (7) Lachish; and (8) Ashkelon.

the surface of the paint; (3) the whole vessel was carefully hand-burnished (polished) before firing; and (4) the punctures and grooves were filled with white calcium carbonate (calcite) after firing.

Groove-outlined punctate designs, filled with a white material (calcite or calcium sulfate [gypsum]), are best attested for a group of black-burnished jugs and juglets, and less commonly for bird-shaped, fish-shaped, and anthropomorphic forms, which occur at sites throughout the Eastern Mediterranean from middle MB IIA to MB IIC (ca. 1800–1550 B.C.) These vessels are collectively referred to as Tell el-Yahudiyeh pottery, after the site in the Nile Delta where the ware and decoration were described by

Petrie (1906: 14–15, pls. 7:3–5, 11–13, 22–26, 35; 8:38–41, 48–50, 52; 8A: 59–66, 68–87).

Unlike the "free-flowing" figural design of the Dolphin Vase, geometric motifs (triangles, rhomboids, etc.) within horizontal and vertical registers predominate among the Tell el-Yahudiyeh types (Kaplan 1980; Bietak 1989). Furthermore, the overall black coloration of the Tell el-Yahudiyeh vessels was achieved by firing the vessels in a reducing atmosphere, whereas the purplish-black (Munsell 2.5YR 2.5/2)⁴ of the animal bodies on the Dolphin Vase is the result of applying a manganese-iron pigmented paint (Noll 1975) and firing the jug in an oxidizing atmosphere. The paint layer, which has flaked

off in places, is clearly separate from the underlying ware, which fired to a reddish-yellow color (Munsell 5YR 6/6–8) under the oxidizing conditions.

Another group of painted jugs and juglets, which lack the punctate decoration but are otherwise similar in form and artistic motives to the Dolphin Vase and Tell el-Yahudiyeh types, are also found at sites throughout the Eastern Mediterranean (Tubb 1983; Bagh 1988). Referred to generically as Levantine Painted Ware, this group appears earlier than the Tell el-Yahudiyeh types, dating primarily to MB IIA (high 1900–1740 B.C.; low 1875–1730 B.C.). Monochrome paints, generally an iron-based red, are most common; occasionally, bichrome red-and-black painted examples occur. Levantine Painted Ware was fired exclusively in an oxidizing atmosphere.

From this brief review, the Dolphin Vase's composite stylistic and technological features are evident. The Tell el-Yahudiyeh and Levantine Painted Ware types also overlap temporally during the transition from MB IIA to MB IIB (high 1740–1720 B.C.; low 1730–1710 B.C.; see n. 2 above), precisely the time frame that general shape criteria would suggest for the Dolphin Vase.

DATING OF TOMB 879

The dating of the archaeological context in which the vase was found poses several problems. Most critically, the tomb-shaft had been robbed in antiquity; and the excavators give no information on the precise location of the objects found nor of their relationship to one another. The tomb was originally intended for three individuals, since each of the three horizontal chambers, opening from the bottom of the shaft, is just large enough for a single burial and since fragments of at least two coffins and one funerary mask were recovered.

The cemetery originally was established in the reign of Amenemhet I for burial of his family and officials close to him. Subsequently, houses for priests and other functionaries involved in his funerary cult were built there. After a period of abandonment, houses of artisans were built here in the later Middle Kingdom, perhaps as a suburb of the capital. Test soundings by a Metropolitan Museum expedition in 1991, to clarify the results of the earlier expedition, showed that the top of the shaft for Tomb 879 was intact under the walls of a later

house. While this finding places the tomb within a stratigraphic sequence, it also opens up the possibility that the original burial groups were contaminated by later materials when the tomb was robbed.

Despite these uncertainties, the objects from the shaft constitute a homogeneous stylistic group, dating from early to middle Dynasty 13 (high 1801–1724 B.C.; low 1759–1682 B.C.), in accord with the date range for the Dolphin Vase based on Syro-Palestinian stylistic criteria (above). Gold foil fragments, which originally covered the coffins in Tomb 879, are inscribed with mutilated hieroglyphs that date from the end of Dynasty 12 through Dynasty 13 (Bourriau 1991: 13; J. Allen, personal communication, June 1993). Native Egyptian pottery—several storage jars and a hemispherical bowl with a characteristic maximum diameter to height ratio of 1.4—are typical of the first half of Dynasty 13 (Do. Arnold 1982; 1988). Four Tell el-Yahudiyeh juglets of the Piriform 1c type (Kemp and Merrillees 1980: 220–25, pl. 31) probably belong to the transition period from late MB IIA into early MB IIB.

CHEMICAL CHARACTERIZATION AND ARCHAEOLOGICAL ORIGIN OF THE DOLPHIN VASE

The Dolphin Vase's unique combination of stylistic and technological features obviates any unequivocal determination of where it was made. Was it a local Egyptian product, made at or near Lisht as some argue (Kemp and Merrillees 1980: 220–25; Merrillees 1978)? Or, was it an import and, if so, from where?

Two of the authors (P.E.M. and G.H.) have been engaged in a neutron activation analysis (NAA) project of Middle Bronze Age pottery, including Tell el-Yahudiyeh, Levantine Painted Ware, and polished slip pottery types, as well as the maritime transport storage container par excellence, the "Canaanite Jar" (Grace 1956: 80–109). The physico-chemical method of NAA has been extensively employed in pottery provenience studies, because of its sensitivity and precision in measuring as many as 35 elements, including rare earths that often characterize a clay source, and because it requires very small samples (50–200 mg) that are nondestructively analyzed.⁵

TABLE 1. Neutron Activation Analysis data for selected Egyptian and Eastern Mediterranean groups and pottery vessels.*

Group/Vessel	Composition ^a									
	N	Na ₂ O (%)	K ₂ O (%)	Rb ₂ O (PPM)	Cs ₂ O (PPM)	BaO (PPM)	Sc ₂ O ₃ (PPM)	La ₂ O ₃ (PPM)	CeO ₂ (PPM)	Eu ₂ O ₃ (PPM)
GAZAGRP	81	0.855	1.63	43.9	1.43	550	18.9	33.7	73.8	1.71
DABAPAL	232	0.673	1.46	35.8	1.36	604	18.5	33.7	73.6	1.63
HILLCTY	20	0.137	3.44	80.5	4.21	169	23.8	24.2	59.2	1.4
MEGIDDO	17	0.469	1.2	35.7	1.02	2680	17.1	36.5	59.8	1.53
SIDON	8	0.267	0.603	49.5	1.43	3483	17.2	32.2	63.5	1.66
BYBLOS	2	0.317	0.685	52.2	2.92	278	19.4	36.1	78.3	1.56
IBNHANI	14	1.47	2.52	108	5.31	627	32.6	35.1	75.3	1.56
ORONTES	8	0.532	3.91	139	5.38	1210	27	61.7	141	2.64
DABAEG	148	1.67	1.77	45.5	1.2	659	34.1	34.4	72.8	2.22
FAYMARL	29	1.58	1.2	49.1	2.56	294	29	45	92	2.09
DOLPHIN	1	0.818	1.35	48.8	2.61	594	22	36	73.6	1.77
DAB ^a A	1	0.664	1.55	40.4	2.12	887	20.1	33.7	65.5	1.49
LISHT1	1	1.49	1.58	56.9	2.88	170	24.2	52.2	115	2.11
LISHT2	1	1.24	1.19	46.5	2.64	449	18.6	36.2	79.8	1.61

*The Dolphin Vase is labeled DOLPHIN. A jug fragment that is similar in type and manufacturing technique to the Dolphin Vase (LISHT1; fig. 5b) and a Tell el-Yahudiyeh bird-shaped rhyton fragment (LISHT2; fig. 5c) are from nearby, contemporaneous Tomb 907 of the Lisht cemetery. A Tell el-Yahudiyeh juglet (DAB^aA; fig. 5a) decorated with fish or dolphins is from Tell el-Dab^a in the northeastern Nile Delta. Additional chemical groups include the following: pottery and clays of the "Gaza group of Middle Bronze Age sites" in southern Palestine (GAZAGRP), a large group of southern Palestinian pottery imports from the Gaza region to Tell el-Dab^a (DABAPAL), pottery and clays from the Palestinian hill country (HILLCTR), a group based on the marl clay source located at Qasr el-Sagha, north of the Fayyum (FAYMARL), and the Egyptian Nile alluvial clay and pottery group for Tell el-Dab^a (DABAEG). IBNHANI is Tell Ibn Hani, a port site along the northern Syrian coast. For other sites and regions, see the text and fig. 2. Data are expressed as mean percentage by weight (%) or parts per million (PPM). The statistical spread (1 standard deviation) is 10 to 20% of the tabulated value for all elements except the more mobile alkalis and alkaline earths, which range as high as 30%. N = number of samples

^aNa₂O = Sodium Monoxide; K₂O = Potassium Monoxide; Rb₂O = Rubidium Monoxide; Cs₂O = Cesium Oxide; BaO = Barium Oxide; Sc₂O₃ = Scandium Sesquioxide; La₂O₃ = Lanthanum Oxide; CeO₂ = Cerium Oxide; Eu₂O₃ = Europium Oxide; Lu₂O₃ = Lutetium Oxide; HfO₂ = Hafnium Oxide; ThO₂ = Thorium Dioxide; Ta₂O₅ = Tantalum Pentoxide; Cr₂O₃ = Chromium Sesquioxide; MnO = Manganese Monoxide; Fe₂O₃ = Ferric Oxide; CoO = Cobalt Oxide; CaO = Calcium Oxide; Sm₂O₃ = Samarium Sesquioxide; Yb₂O₃ = Ytterbium Oxide.

Relating the chemical composition of a particular ancient pottery sample to a given clay source, thereby "fingerprinting" the pottery and its presumed place of manufacture, is based on what has become known as the Provenience Postulate (Weigand, Harbottle, and Sayre 1977: 15–34). Briefly, the assumption is made that the chemical variation within a given clay source is less than that between different sources. A native clay, however, was often modified by the ancient potter. Inorganic aplastics (temper) or organic materials might be added to the clay body to improve its workability, drying and firing properties, and functionality (Rye 1981). If these inclusions are relatively "pure" (e.g., quartz, calcite, or straw), the diluent effect on the chemical composition of an ancient sample will be spread across the range of elements and correction factors (e.g., least-means fitting) can be readily applied. The addition of complex heavy minerals, which can unpredictably enhance or diminish cer-

tain elemental concentrations, is less easily corrected for statistically.

A range of univariate and multivariate algorithms—means and standard deviations, and correlational, clustering, and principal components analyses of a range of elements—is used to define local chemical groups of ancient pottery, with widely divergent samples (outliers) being excluded. Archaeological and geological criteria are important in refining and testing these groups, whether well-dated pottery types, clays from specific geochemical regimes, clay beds within a single deposit, or others. For example, cooking pots, walls, and kilns, made of mudbrick (sunbaked clay) are usually made of local clay and are not transported to another site. The NAA analyses of such samples should then confirm a hypothesized local group based on other pottery types. This approach is essential when an ancient clay source has been totally exploited or systematic clay sampling has not yet been carried out in a region.

TABLE 1. (cont.)

<i>Composition^a</i>										
Lu ₂ O ₃ (PPM)	HfO ₂ (PPM)	ThO ₂ (PPM)	Ta ₂ O ₅ (PPM)	Cr ₂ O ₃ (PPM)	MnO (PPM)	Fe ₂ O ₃ (%)	CoO (PPM)	CaO (%)	Sm ₂ O ₃ (PPM)	Yb ₂ O ₃ (PPM)
0.596	11.3	8.41	1.68	134	951	5.12	23.5	12.1	6.78	3.67
0.547	7.13	7.66	1.62	149	847	4.82	21.1	15.9	6.52	3.39
0.471	4.25	7.41	0.989	123	435	4.75	15.9	9.42	5.62	2.54
0.557	4.81	5.41	1.27	192	822	4.23	20.1	20.1	5.92	2.43
0.617	5.64	6.52	1.62	149	622	4.32	24.6	20.4	6.82	3.17
0.515	7.64	9.55	1.36	163	757	5.2	28.6	12.5	7.38	2.79
0.528	4.7	11.1	1.38	493	1570	7.52	40.1	12.6	6.32	2.76
0.793	8.05	20.6	2.52	174	311	6.97	26.9	8.8	12.5	3.98
0.579	7.64	6.67	2.06	188	1410	8.93	42.3	15.9	7.41	3.25
0.568	9.66	10.3	2.34	155	388	6.81	24.8	15.9	8.09	3.36
0.55	4.52	7.41	1.22	186	550	5.75	14.9	29	7.06	2.86
0.506	5.22	9.27	1.6	146	684	5.11	19.6	18.1	6.49	2.98
0.661	8.53	12.68	2.82	183	468	7.18	34	11.7	9.51	3.56
0.53	5.74	8.32	1.57	200	270	5.11	16.9	15.9	6.81	3.03

The Middle Bronze Age NAA pottery study to date includes 578 pottery and clay samples from the key site of Tell el-Dab^a, the ancient "Hyksos" capital of Avaris (below) in the northeastern Nile Delta (Bietak 1986; 1991). To date, an additional 760 pottery and clay samples from 55 coastal and inland sites of Syria, Lebanon, Jordan, and Israel—including Ras Shamra/ancient Ugarit, Tell Kazel, Tell Mardikh/ancient Ebla, Hama, Byblos, Sidon, Kamid el-Loz, Megiddo, Tel Aphek, Jaffa, Ashkelon, Tell el-^cAjjul, Tell Beit Mirsim, Beth Shan, Pella, Jericho, Tell el-Fukhar, the Baq^cah Valley of Transjordan, Bab edh-Dhra^c, etc. (fig. 2)—have been analyzed. Another 119 pottery and clay samples have been tested from sites along the Middle and Upper Nile—Kahun and Dahshur near Lisht, el-Amarna, Abydos, etc. (fig. 2)—that range in date from the Old to the New Kingdom (ca. 2700–1070 B.C.). Previous Brookhaven projects (e.g., Kaplan 1980; Brooks et al. 1974: 48–80), accounting for 1208 pottery and clay samples from 79 more Levantine and Egyptian sites, complete the data bank for this region.

The clays that have thus far been analyzed date from the Lower Cretaceous period to recent times and derive from deposits throughout the Levant and Egypt. The red loess clays of the southern Palestinian coastal region, the yellow limestone-derived clays of the Palestinian hill country, Transjordanian smectites and kaolin clays, Egyptian alluvial and marl clays, etc., are well represented in the data bank.

The Old World data bank has excellent temporal and spatial coverage of other regions of the Near East and Mediterranean, including the Sudan,

Greece, Iraq, Iran, and parts of Turkey. This wide areal coverage, coupled with large numbers of samples for locally defined groups, enables us to apply powerful multivariate statistics in determining the archaeological origin of the Dolphin Vase.

It is quite common for the elements in clays and minerals to covary with one another. For example, the high correlation (> 0.99) of iron (Fe) and scandium (Sc), both trivalent ions of about equal size, in nature is well known. Univariate statistics can be very misleading if this relationship goes unrecognized. Two Palestinian clay sources of importance in our study—the red loess clay of the southern coast and the yellow hill country clay—have similar univariate distributions, but have clearly distinguishable Sc/Fe ratios (Brooks et al. 1974: 48–80).

If the variance-covariance matrix for many elements of a presumed local group is calculated, a new set of standardized orthogonal coordinates (eigenvectors) can be defined in multidimensional Mahalanobis space that takes advantage of elemental correlations (Harbottle 1991: 413–24). For the statistical calculations, the oxide data (table 1) were converted to logarithms, since many chemical elements appear to be lognormally distributed in nature, and are also standardized by this procedure (see n. 5 above). The Mahalanobis distance of a given sample from the origin or centroid of the group is directly related to the probability of the group membership of that sample, assuming a multivariate normal distribution (Sayre 1975). Using the oxides of 15 elements in the calculation, it has been estimated by comparisons of the large Brookhaven New

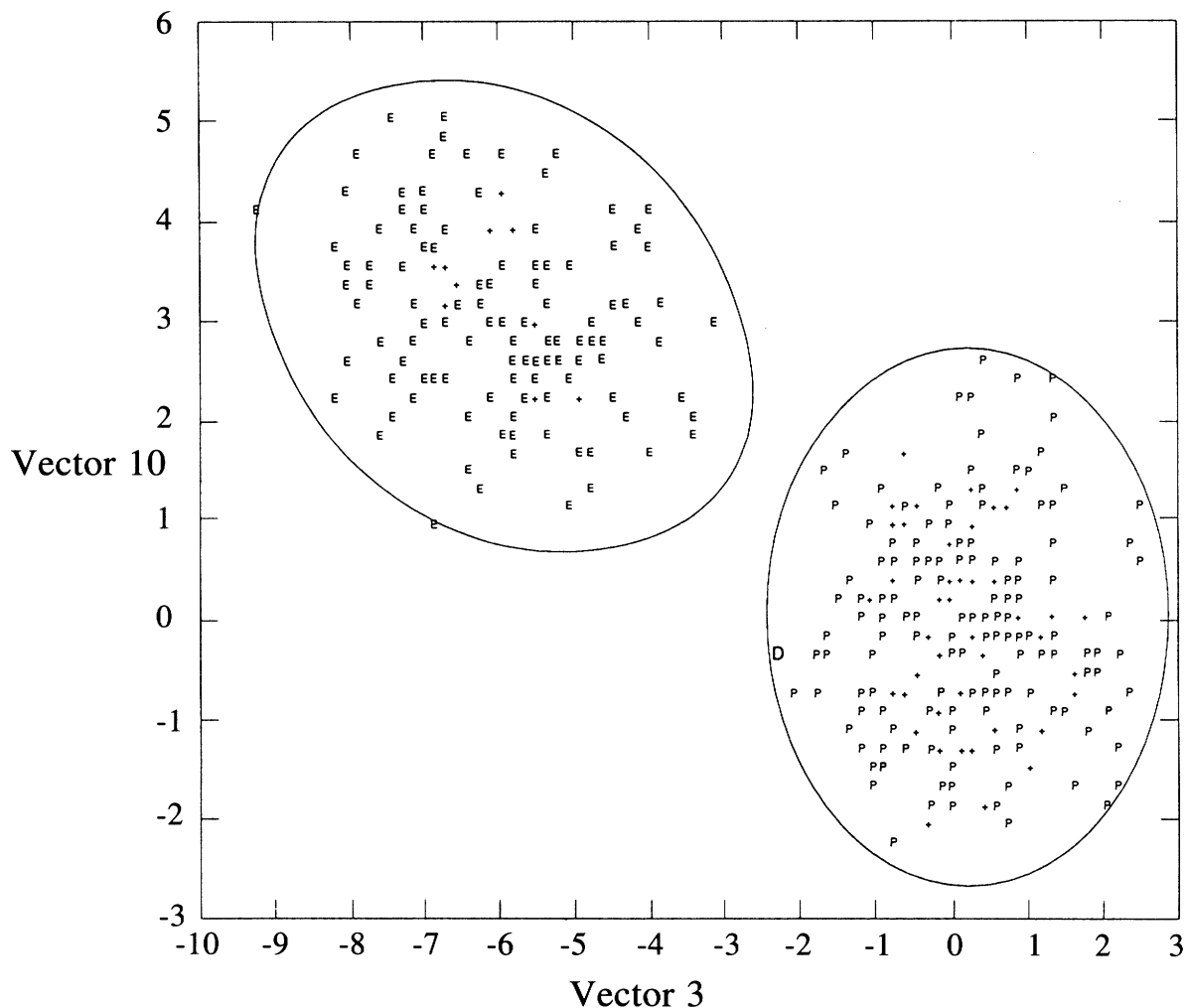

Fig. 3. Plot of eigenvector 3 and 10 scores, with variance–covariance matrices “highly loaded” for Eu/Th and Hf/Mn, respectively. The Mahalanobis distance probability calculations, here indicated by a 95% confidence ellipse for samples belonging to a group, were carried out on the neutron activation analysis data of a large group of Middle Bronze Age pottery imports (labeled P; multiple examples at the same coordinates denoted by +) from the “Gaza group of Middle Bronze Age sites” in southern Palestine, which were found at the Hyksos capital of Avaris (modern Tell el-Dab^a) in the northeastern Nile Delta. This group is clearly distinguished from another large group of locally produced Middle Bronze Age pottery made of Egyptian Nile alluvial clay (labeled E) from the same site. The Dolphin Vase (labeled D) is on the periphery of the southern Palestinian group.

World pottery data bank (about 10,000 samples) against the Old World data bank (about 5000 samples) that the accidental assignment of a sample at a Mahalanobis probability of 1% is nil for these two archaeologically and geochemically distinct regions (Harbottle 1991). Within a more circumscribed region, such as the Eastern Mediterranean, where the same or related geological processes have been at work, this unique chemical “fingerprinting” is not assured. But with high correlations between many elements, such as is characteristic of Levantine clays and pottery, it is possible to achieve extremely good

results. A Mahalanobis probability above 5% for a sample tested against a group with a high sample number to variate ratio is a strong guarantee that it belongs to that group.

Using the oxides of 15 elements (sodium [Na], potassium [K], cesium [Cs], rubidium [Rb], barium [Ba], scandium [Sc], europium [Eu], thorium [Th], hafnium [Hf], manganese [Mn], cobalt [Co], chromium [Cr], iron [Fe], samarium [Sm], and ytterbium [Yb]) and not correcting for dilution or concentration effects, the Dolphin Vase has a Mahalanobis distance probability of 5.6% of belonging to a tight chemical

group of 268 pottery vessels that were recovered from Middle Bronze levels at Tell el-Dab^ca (see table 1). These vessels comprise 46% of the Tell el-Dab^ca corpus that has been tested by NAA, and include 201 Canaanite Jars as well as other Syro-Palestinian types (Tell el-Yahudiyeh, Levantine Painted Ware, and polished slip pottery). Correcting for calcite dilution, the Mahalanobis distance probability for the Dolphin Vase is 8.1%.

Thirty-six Middle Bronze Age pottery samples from the so-called "Gaza group of Middle Bronze Age sites"—a number of relatively large city-states centered on Gaza, extending from Tell el-Far^cah South to Ashkelon along the coastal plain, and including Tell el-^cAjjul, Tell el-Far^cah South, Tell Jemmeh, Tel Haror, and Tell Beit Mirsim, and Lachish farther inland (fig. 2)—also formed a tight chemical group with 14 red loess clays of the region (table 1). Using the mean concentrations of the oxides of 15 elements, the Mahalanobis distance probability that the Gaza group of pottery and clays belongs to the large, well-defined Dab^ca group is 98.8%. Remarkably, all other well-defined local groups in the Old World data bank had a 0% probability of belonging to the Dab^ca group. It is virtually certain therefore that the Dolphin Vase and the 268 pottery vessels found at Tell el-Dab^ca were produced in southern Palestine and exported to Lisht and the northeastern Nile Delta, respectively.

The Mahalanobis distance probabilities can be partly represented in two-dimensional space by plotting the vector scores on any pair of eigenvectors (or principal components) for a group. In fig. 3, for example, two eigenvectors (denoted 3 and 10), whose variance-covariance matrices are "highly loaded" for Eu/Th and Hf/Mn respectively, show good discrimination between the southern Palestinian and Nile alluvial clay groups at Tell el-Dab^ca.

The Mahalanobis distance probability assignment of the Dolphin Vase to the Gaza region of southern Palestine is further borne out by searches for the closest chemical matches in mean Euclidean distance (MED) space (defined as the square root of the mean of the sum of the squares of the differences between the log elemental concentrations of any given pair of samples). Although correlational effects are excluded from this calculation, excellent results can be obtained with 15 elements, because the variance in the MED approaches zero as the inverse of the number of variables (Harbottle 1991). The closest "match" for the Dolphin Vase, with an MED of 0.079, belonged to the Dab^ca southern Palestinian group. An MED of less than 0.08 has been empiri-

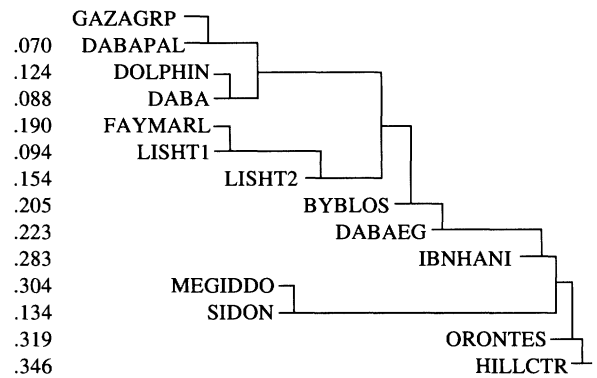

Fig. 4. Dendrogram, based on a hierarchical aggregative clustering algorithm and the neutron activation analysis means of the oxides of 15 elements for each group (table 1). The mean Euclidean distance to each node in the dendrogram is listed along the ordinate. Note that the Dolphin Vase (DOLPHIN) forms a cluster with the red loess clay groups of pottery from the "Gaza group of Middle Bronze Age sites" (labeled GAZAGRP), and the imported southern Palestinian group at Tell el-Dab^ca (DABAPAL), and a Tell el-Yahudiyeh juglet showing fish or dolphins from Dab^ca (DAB^cA; see fig. 5a caption). Another cluster is comprised of two other pottery vessels of Syro-Palestinian types from the Lisht cemetery (LISHT1 and LISHT2; see fig. 5b, c captions) that are made of Egyptian marl clay (FAYMARL). For other selected Egyptian and Eastern Mediterranean groups, see the text, table 1 note, and fig. 2.

cally determined to be indicative of group membership, especially in conjunction with a Mahalanobis distance probability greater than 5% (above).

It would be of interest to know at which Middle Bronze site in the Gaza region the Dolphin Vase was manufactured. While Tell el-^cAjjul pottery and red loess clays collected in Gaza yield very high Mahalanobis distance probabilities (exceeding an average of 50% for 23 samples) of belonging to the Dab^ca southern Palestinian group, the Dolphin Vase's probability was only in the 5 to 10% range. As a peripheral member of the southern Palestinian group (cf. fig. 3), the Dolphin Vase may originate from a site located some distance from ^cAjjul and Gaza. A definitive answer is elusive, because of the very similar chemical composition of red loess clay in the region.

The MED calculations in multidimensional space can also be partly represented by two-dimensional graphical representations, such as the dendrogram in fig. 4 that was generated using an hierarchical aggregative clustering algorithm and the means of the 15 elements for each group (table 1). The dendrogram shows a close chemical relationship between the Dolphin Vase and the Dab^ca southern Palestinian and Gaza groups. A Tell el-Yahudiyeh



Fig. 5. a. Tell el-Yahudiyeh Piriform 1a juglet, from Tell el-Dab^ca (ancient Avaris), excavation no. 1734/Kunsthistorisches Museum, Vienna no. WA1691, area All m/11, Planum 6, Stratum G; b. Tell el-Yahudiyeh jug shoulder and neck fragment, from Tomb 907 at Lisht, Metropolitan Museum of Art no. 22.1.213/Oriental Institute, University of Chicago no. 28257; c. bird-shaped rhyton fragment, from Tomb 907 at Lisht. Metropolitan Museum of Art no. 22.1.212/Oriental Institute, University of Chicago no. 28256. Scale 1:2 (a); 3:4 (b, c). Sections b and c courtesy of the Oriental Institute, University of Chicago.

juglet (fig. 5a) (Bietak 1970: pl. 19c; 1986: 238, fig. 3 [fig. 5a here]) from Tell el-Dab^ca, with a line of “fish” that may be schematically rendered dolphins, belongs to the same grouping (below). Other Egyptian and Syro-Palestinian groups are very far removed in MED hyperspace from the southern Palestinian grouping.

RELATED POTTERY VESSELS

Two other pottery vessels from the Lisht cemetery (fig. 5b, c) are closest chemically to an Egyptian marly clay deposit, which outcrops north of the Fayyum (fig. 2) as the Qasr el-Sagha formation of Pleistocene date, not far from Lisht (Tobia and Sayre 1974; also see Said 1962). The jug shoulder and neck fragment (fig. 5b), like the Dolphin Vase, was fired to a yellowish-red (Munsell 5YR 5/6–8) ware in an oxidizing atmosphere, and has a triple-stranded handle, outwardly folded rim, and white-filled grooves running around the shoulder. Only a

small part of a geometric design on the body—a white calcite-filled punctate triangle below the handle—is preserved. Its production, as well as that of the more standard Tell el-Yahudiyeh bird-shaped rhyton fragment (fig. 5c) in a locally available Egyptian marl clay, using techniques similar to those for the Dolphin Vase, demonstrates that potters with the requisite skills were resident in the Nile Valley by middle Dynasty 13 (high 1724 B.C.; low 1682 B.C.). Major changes in the native pottery industry at Lisht were already evident by the time of the second king of Dynasty 12, Senwosret I (high 1959–1914 B.C.; low 1917–1872 B.C.).

Previous studies of the Dolphin Vase have stressed the uniqueness of its animal designs (Kantor 1965: 23–24, fig. 6; Kemp and Merrillees 1980: 220–25; Merrillees 1978), especially the fact that pottery vessels decorated with dolphins are yet to be found in the Eastern Mediterranean or Egypt. Yet, lines of “fish,” possibly dolphins, appear on Tell el-Yahudiyeh juglets from Tell ed-Dab^ca (fig. 5a; above) and Dahshur (Do. Arnold 1977; pl. 4b). Tell

el-Yahudiyeh bird-shaped (e.g., fig. 5c) and fish-shaped rhyta are also quite common throughout the Eastern Mediterranean and Egypt (Kaplan 1980).

If the bird motif on the Dolphin Vase, as well as other stylistic and technological features, are not foreign to southern Palestine, parallels for the dolphin motif may be expected in future excavations. An ancient potter in the Gaza region would have been familiar with the migrations of large wading birds and dolphins along the Mediterranean coast, which occur today, and might well have combined these motifs in a design during a time of innovative pottery production.

CULTURAL AND TECHNOLOGICAL IMPLICATIONS

Beyond determining where a unique pottery vessel was made, this study contributes to the understanding of cultural and technological developments for a poorly known period in Egyptian

history. The deposition of the Dolphin Vase in a tomb at Lisht, the capital of Middle Kingdom Egypt, probably preceded by a half century or less the rise to power of a Semitic population, the "Hyksos" (a term derived from Egyptian *ḥkꜣw ḥꜣswt*—"rulers of foreign lands"), at Avaris (modern Tell el-Dab^ca) in the northeastern Nile Delta. Traditionally, the Hyksos were viewed as foreign barbarians, who stormed into Egypt and destroyed the major cities, including Lisht (see Josephus, *AgAp*, sect. 14). This NAA study, by determining that the Dolphin Vase belongs to the same chemical compositional group as the vast majority of the imported pottery found at Tell el-Dab^ca, suggests that trade relations, presumably of a more peaceful nature, initially existed between the Hyksos, the native Egyptian dynasty, and the Gaza region, the nearest region to Egypt with substantive urban development. The popularity of southern Palestinian stylistic and technological models is reflected in the local production of the imported pottery types, using Egyptian marl clay, at Lisht.

ACKNOWLEDGMENTS

This article, the first in a projected series of publications dealing with Levantine pottery imports into Egypt during the Middle Bronze Age, is affectionately dedicated to the late Mrs. Joan Huntoon. Mrs. Huntoon began the large-scale neutron activation analysis project pottery of Tell el-Dab^ca and Eastern Mediterranean clays and pottery wares and processed most of the samples between 1984 and 1986 at Brookhaven National Laboratory, under contract DE-AC02-76CH-00016 with the U. S. Department of Energy.

The samples from the Dolphin Vase and the two other vessels from the Lisht cemetery were analyzed at the University of Missouri Research Reactor (MURR), under the direction of M. D. Glascock, with support from a National Science Foundation grant (BNS-8801707). Statistics,

employing the battery of programs developed at Brookhaven, were carried out on the University Museum VAX computer, with the support of P. Chase. The Dolphin Vase was kindly X-rayed and the paint and white filling analyzed using SEM-EDS (Scanning Electron Microscopy-Energy Dispersive Spectrometry) by A. Heywood and M. T. Wypyski of the Objects Conservation Department of The Metropolitan Museum of Art. The drawing of the Dolphin Vase was done by B. Girsh of The Metropolitan Museum. The map and other graphics were prepared by P. Zimmerman of MASCA using CANVAS 4.0 on an Apple Macintosh computer. Earlier versions of this article were reviewed by Dorothea Arnold, J. Beaudoin, M. Bietak, S. J. Fleming, M. D. Glascock, and M. Tadmor.

NOTES

¹Egyptian dynastic dates are according to the corrected "high" and "low" options of K. A. Kitchen (1987: 43-44, 47, tables 1, 2; see also the supplement to the colloquium [Kitchen 1989: 152-53]).

²According to Lilyquist 1993: 41-44, artifacts naming these pharaohs are associated with later MB II and even early Late Bronze Age material in some of the Byblos royal tombs.

³The archaeological dating in this article follows the so-called "middle chronology" of J. M. Weinstein (1992: table 1).

⁴Color notations are according to the *Munsell Soil Color Charts* (Munsell Color Company, Baltimore, 1975).

⁵Information on sample preparation, irradiation procedures, and processing of gamma ray spectra can be found in Harbottle 1976 and Neff 1992.

REFERENCES

- Arnold, Do.
 1977 Zur Keramik aus dem Taltempelbereich der Pyramide Amenemhets III. in Dahschur. *Mitteilungen des Deutschen Archäologischen Instituts Abteilung Kairo* 33: 21–29.
 1982 Keramikbearbeitung in Dahschur 1976–1981. *Mitteilungen des Deutschen Archäologischen Instituts Abteilung Kairo* 38: 25–65.
 1988 Pottery. Pp. 106–46 in *The Pyramid of Senwosret I*, by Di. Arnold. The South Cemeteries of Lisht, vol. 1. New York: Metropolitan Museum of Art.
- Bagh, T.
 1988 Bemalet MBIIA keramik og bemalet Tell el-Yahudiyeh ware fundet i Ægypten. Unpublished Masters thesis, University of Copenhagen.
- Biers, W. R., and McGovern, P. E., eds.
 1990 *Organic Contents of Ancient Vessels: Materials Analysis and Archaeological Investigation*. MASCA Research Papers in Archaeology 7. Philadelphia: Museum Applied Science Center for Archaeology, University of Pennsylvania.
- Bietak, M.
 1970 Vorläufiger Bericht über die erste und zweite Kampagne der Österreichischen Ausgrabungen auf Tell Ed-Dab^ca im Ostdelta Ägyptens (1968). *Mitteilungen des Deutschen Archäologischen Instituts Abteilung Kairo* 26: 15–42.
 1986 *Avaris and Piramesse: Archaeological Exploration in the Eastern Delta*. 2nd ed., rev. London: British Academy.
 1989 Archäologischer Befund und historische-Interpretation am Beispiel der Tell el-Yahudiya Ware. Pp. 7–34 in *Akten des vierten internationalen Ägyptologenkongresses München 1985*, vol. 2, ed. S. Schoske. Hamburg: Buske.
 1991 Egypt and Canaan during the Middle Bronze Age. *Bulletin of the American Schools of Oriental Reserach* 281: 27–72.
- Bourriau, J.
 1991 Patterns of Change in Burial Customs during the Middle Kingdom. Pp. 3–20 in *Middle Kingdom Studies*, ed. S. Quirke. New Malden, Surrey: SIA.
- Brooks, D.; Bieber, A. M., Jr.; Harbottle, G.; and Sayre, E. V.
 1974 Biblical Studies through Activation Analysis of Ancient Pottery. Pp. 48–80 in *Archaeological Chemistry*, ed. C. W. Beck. Advances in Chemistry 138. Washington: American Chemical Society.
- Czernohaus, K.
 1988 *Delphindarstellungen von der minoischen bis zur geometrischen Zeit*. Gothenburg: Åström.
- Grace, V. R.
 1956 The Canaanite Jar. Pp. 80–109 in *The Aegean and the Near East: Studies Presented to Hetty Goldman on the Occasion of Her Seventy-fifth Birthday*, ed. S. S. Weinberg. Locust Valley, NY: Augustin.
- Harbottle, G.
 1976 Activation Analysis in Archaeology. *Radiochemistry* 3: 33–72.
 1991 Efficiencies and Error-rates of Euclidean and Mahalanobis Searches in Hypergeometries of Archaeological Ceramic Compositions. Pp. 413–24 in *Archaeometry 90*, eds. E. Pernicka and G. A. Wagner. Basel: Birkhauser.
- Houlihan, P. F.
 1988 *The Birds of Ancient Egypt*. The Natural History of Egypt, vol. 1. Cairo: American University of Cairo.
- Kantor, H. J.
 1965 The Relative Chronology of Egypt and Its Foreign Correlations before the Late Bronze Age. Pp. 1–46 in *Chronologies in Old World Archaeology*, ed. R. W. Ehrich. Chicago: University of Chicago.
- Kaplan, M. F.
 1980 *The Origin and Distribution of Tell el Yahudiyeh Ware*. Studies in Mediterranean Archaeology, vol. 62. Gothenburg: Åström.
- Kemp, B. J., and Merrillees, R. S.
 1980 *Minoan Pottery in Second Millennium Egypt*. Mainz: von Zabern.
- Kitchen, K. A.
 1987 The Basics of Egyptian Chronology in Relation to the Bronze Age. Pp. 37–55 in *High, Middle or Low?: Acts of an International Colloquium on Absolute Chronology Held at the University of Gothenburg, 20th–22nd August 1987*, part 1, ed. P. Åström. Gothenburg: Åström.
 1989 Supplementary Notes on “The Basics of Egyptian Chronology.” Pp. 152–59 in *High, Middle or Low?: Acts of an International Colloquium on Absolute Chronology Held at the University of Gothenburg, 20th–22nd August 1987*, part 3, ed. P. Åström. Gothenburg: Åström.
- Lilyquist, C.
 1993 Granulation and Glass: Chronological and Stylistic Investigations at Selected Sites, ca. 2500–

- 1400 B.C.E. *Bulletin of the American Schools of Oriental Research* 290–291: 29–94.
- Mace, A. C.
1921 The Egyptian Expedition, 1920–1921. *Bulletin of the Metropolitan Museum of Art* 16:5–19.
- McGovern, P. E., ed.
1989 *Cross-Craft and Cross-Cultural Interactions in Ceramics*. Ceramics and Civilization, vol. 4. Westerville, OH: American Ceramic Society.
- Merrillees, R. S.
1978 El-Lisht and Tell el-Yahudiya Ware in the Archaeological Museum of the American University of Beirut. *Levant* 10: 75–98.
- Montet, P.
1928–1929 *Byblos et l’Égypte*. Bibliothèque Archéologique et Historique 11. Paris: Geuthner.
- Neff, H., ed.
1992 *Chemical Characterization of Ceramic Pastes in Archaeology*. Monographs in World Archaeology 7. Madison, WI: Prehistory.
- Noll, W.
1975 Painting of Ancient Ceramics. *Angewandte Chemie* (International ed.) 14: 602–13.
- Petrie, W. M. F.
1906 *Hyksos and Israelite Cities*. British School of Archaeology in Egypt and Egyptian Research Account, vol. 12 (double volume). London: Quaritch.
- Rye, O. S.
1981 *Pottery Technology: Principles and Reconstruction*. Manuals on Archeology 4. Washington: Taraxacum.
- Said, R.
1962 *The Geology of Egypt*. New York: Elsevier.
- Sayre, E. V.
1975 Brookhaven Procedures for Statistical Analyses of Multivariate Archaeometric Data. Unpublished Brookhaven National Laboratory Report BNL-23128, Upton, NY.
- Tobia, S. K., and Sayre, E. V.
1974 An Analytical Comparison of Various Egyptian Soils, Clays, Shales, and Some Ancient Pottery by Neutron Activation. Pp. 99–128 in *Recent Advances in Science and Technology of Materials*, vol. 3, ed. A. Bashay. New York: Plenum.
- Tubb, J. N.
1983 The MBIIA Period in Palestine: Its Relationship with Syria and Its Origin. *Levant* 15: 49–62.
- Warren, P., and Hankey, V.
1989 *Aegean Bronze Age Chronology*. Bristol: Bristol Classical.
- Weigand, P. C.; Harbottle, G.; and Sayre, E. V.
1977 Turquoise Sources and Source Analysis: Mesoamerica and the Southwestern U.S.A. Pp. 15–34 in *Exchange Systems in Prehistory*, eds. T. K. Earle and J. E. Ericson. New York: Academic.
- Weinstein, J. M.
1982 Review of *Minoan Pottery in Second Millennium Egypt*, by B. J. Kemp and R. S. Merrillees. *Journal of the American Research Center in Egypt* 19: 157–60.
1992 The Chronology of Palestine in the Early Second Millennium B.C.E. *Bulletin of the American Schools of Oriental Research* 288: 27–46.